

STELLA DI CAFFE - 3 GROUPES / UNITS

SDC 3

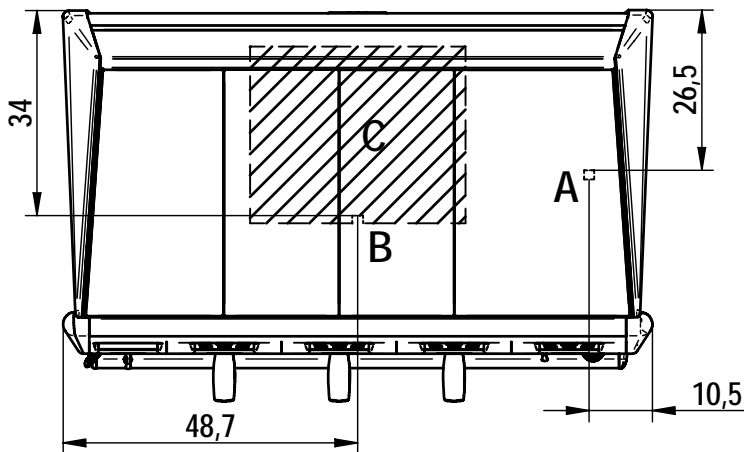
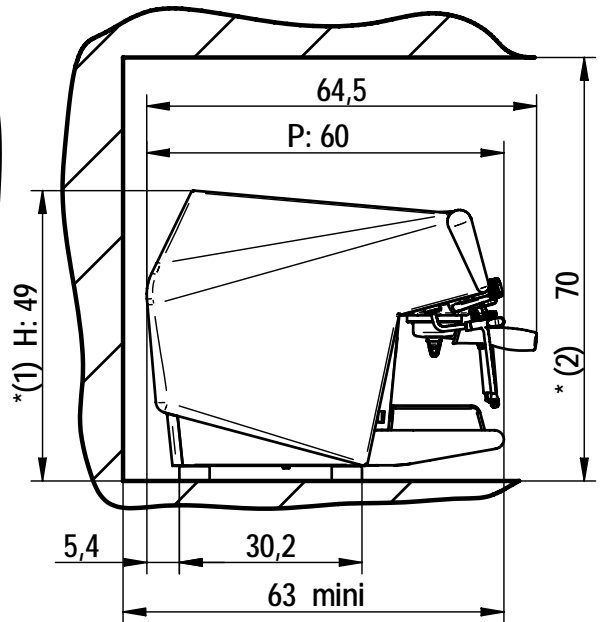
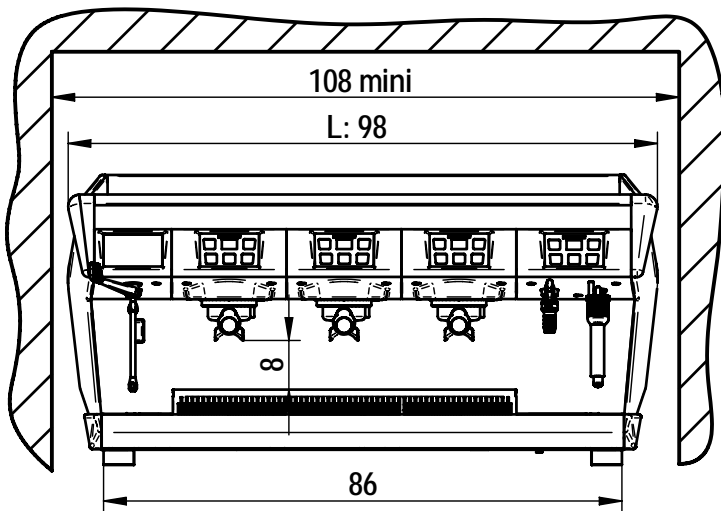

* Model NSF

(1) H : 57

(2) 78

Encombrement (cm) Measures	H	H NSF	L	P
	49	57	98	60
Poids / Weight	92 kg			
Capacité / Capacity				
Chaudière vapeur Steam boiler	14.3L			
Chaudière groupe Unit boiler	1.65L / groupe / unit			
Puissance installée Power capacity	230 V - 12550 W			
P. Maxi simultanée Maximum simultaneous power	230V - 6700 W			
Adoucisseur si besoin / Softener if necessary				
Réglages / Adjustements				
Pression vapeur / Steam pressure			1 bar	
Pression pompe / Pump pressure			9 bar	
Soupape HP / HP valve			13 bar	

		Machine fournie avec: Machine supplied with:
A	Arrivée eau Water inlet	Tube flexible L 1.6 m Raccord 1/2F Flexible pipe L 1.6 m Connection 1/2F (Prevoir tube Ø10-12 mini + raccord 1/2 M) (Tube Ø10-12 mini + connection 1/2 M to provide)
B	Vidange Drain	Tube flexible Ø22 L 1.6 m Flexible tube Ø22 L 1.6 m (Tube Ø 32 mini à prévoir / to provide)
C	Zone de passage des cables & tubes Cables and tubes area	
D	Branchement électrique Electric connection	Fil 5 brins L 1.6 m Cable 5 wires L 1.6 m Raccordement à la terre obligatoire ground connection compulsory

	P (kW)	I mono (A)	I tri + N (A)	I tri (A)
Puissance électrique Electric supply				
230V mono - 400V tri	6.7	30	10	
240V mono - 415V tri	7.7	32	11	
200V tri	5.4	X	X	16
230V tri	6.7			18
240V tri	7.7			19